

# MBC-510

## Manual Spray Gun with Removable-Head

Combining a drop forged aluminum body with a forged removable spray head, the MBC-510 spray gun is ideal for applications that require maximum output and quick changeovers.

- Removable spray head allows for reduced downtime on nozzle combination changeovers.
- MBC spray guns have nickel-plated brass fluid passages and stainless steel fluid tip and needle.
- Ideal for zinc coatings.
- Applications include oil platforms, corrosion control and bridge maintenance coatings.

### Ordering Information

The following air cap and fluid tip set-ups are factory assembled for immediate delivery.

Part No.	
MBC-510-30EX	MBC-510-64HDD
MBC-510 64HDE	MBC-510-704E

*These guns with fluid tip and needle can be ordered separately without air cap and retaining ring:*

Part No.	
MBC-510-D	MBC-510-FF
MBC-510-E	MBC-510-FX
MBC-510-EX	

### Technical Specifications:

Body:	Drop forged aluminum
Weight:	27 oz. (756 gr) with air cap and ring
Air Inlet:	100 psi max (7 bar), 1/4" NPS (M)
Fluid Inlet:	150 psi max (10 bar), 3/8" NPS (M)
Fluid Passages:	Nickel-plated brass
Wetted Parts:	Nickel-plated brass 300, 400-grade stainless steel
Feed Type:	Pressure feed
(Material Supply)	Suction feed
Service Bulletin:	<b>SB-2-301</b>
Gun Repair Kit:	<b>KK-4058-1</b>

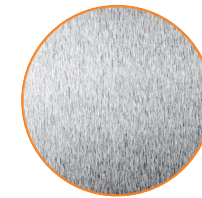
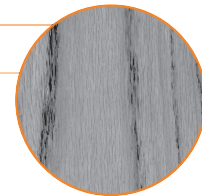
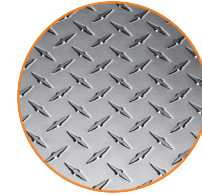

### Accessories

- Hose assemblies, air control, pressure tanks, cups, gun and hose cleaning equipment and other accessories are also available.

Chart 1 Fluid Tip (Nozzle), Air Cap and Needle Combinations

Air Cap Sizes Order From Chart 2	Fluid Tip and Needle Size Order From Chart 3					
	AC	D	E	EX	FF	FX
Tip Orifice in./mm	.110 2.8	.086 2.2	.070 1.8	070 1.8	.055 1.4	.042 1.1
24		P	P			P
30			P	S	P	P
58			P/S	S	P	P
62HD	P					
64HD			P			
80				S		
704			P		P	
765			P		P	P
777			P		P	
797			P		P	
9000				S		

P = Pressure Feed Combination  
S = Suction Feed Combination

MBC-510 Manual Spray Gun with Removable-Head

Refer to Service Bulletin: SB-2-301

# MBC-510 Manual Spray Gun with Removable-Head

## Chart 2 Air Caps/ Retaining Rings

No. on Cap Order →	Ref. No. (1) Air Cap With Ring	Ref. No. (3) Air Cap Less Ring
24		AV-40-24
30	MB-4039-30	
58	AV-439-58	
62HD	MB-4039-62HD	
64HD	MB-4039-64HD	
80	MB-4039-80	
704		AV-1239-704
765		AV-1239-765
777		31767-777
797		AV-1239-797
9000	AV-440-9000	

(3) Retaining ring required (MBC-368)

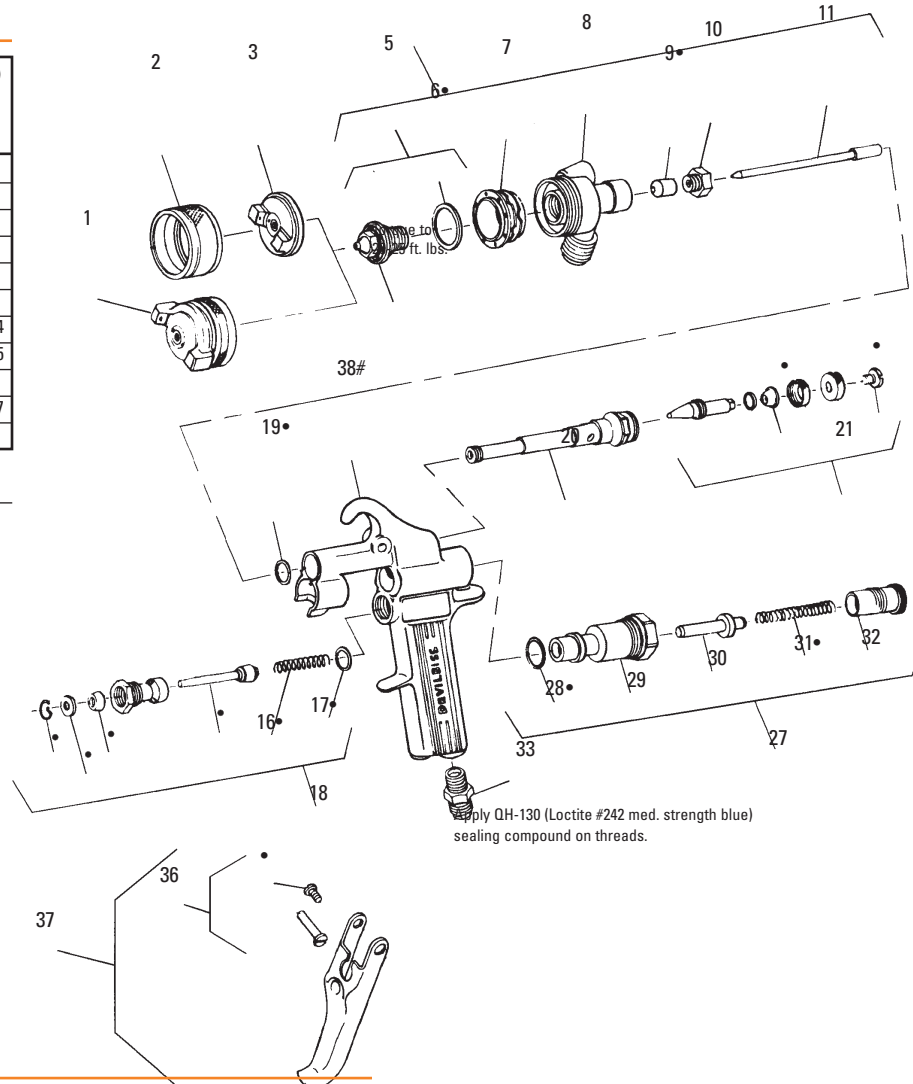

Apply QH-130 (Loctite #242 med. strength blue) sealing compound on threads.

### Parts List

Ref. No.	Model No.	Description	Ind. Parts Required
1	See Chart 2	Air Cap/Retaining Ring	1
2	MBC-368	Retaining Ring for Ref. No. 3 & 4	1
3	See Chart 2	Air Cap Less Retaining Ring	1
4	See Chart 3	Sprayhead Assembly	1
5	See Chart 3	Fluid Tip and Gasket Assembly	1
*6	AV-1-K5	Gasket Kit (Kit of 5)	1
7	MBC-1225	Baffle	1
8	P-MBC-402	Sprayhead Body	1
*9	A-23-K10	Packing Kit (Kit of 10)	1
10	MB-19-K5	Packing Nut Kit (Kit of 5)	1
11	See Chart 3	Fluid Needle	1
*16	MBD-12-K25	Spring Kit (Kit of 25)	1
*17	JGS-72-K10	Gasket Kit (Kit of 10)	1
18	JGS-449-1	Valve Assembly	1
*19	MBC-1226-K10	Gasket Kit (Kit of 10)	1
20	MBC-67	Locking Bolt	1
21	MBC-498-1	Fan Adjustment Valve	1
27	MBC-415	Cylinder Assembly	1
*28	CV-5-K5	Gasket Kit (Kit of 5)	1
30	MBC-33	Plunger	1
*31	MBC-29	Spring	1
32	MBC-39	Screw	1
33	P-MB-51	Air Inlet Adapter 1/4" NPS	1
36	JGS-478	Stud and Screw Kit (3 studs, 5 screws in kit)	1
37	JGS-477-1	Trigger, Stud and Screw Kit (Kit includes 1 each)	1
#38	P-MBC-428-3	Spray gun less spray head	1

### Chart 3 Fluid Tips (Nozzles) and Needles

Fluid Tip Number →	Ref. No. 4 Sprayhead Assy.	Ref. No. 11 Fluid Needle	Optional 303 S/S Tip Needle U.H.M.W. Poly. No. on Tip 5
AV-2115-AC		MBC-496-C	
AV-2115-D	P-MBC-430-D	MBC-496-DEX	AV-4915-D
AV-2115-E	P-MBC-430-E	MBC-444-E	AV-4915-E
AV-2115-EX	P-MBC-430-EX	MBC-496-DEX	
AV-2115-FF	P-MBC-430-FF	MBC-444-FF	AV-4915-FF
AV-2115-FX	P-MBC-430-FX	MBC-444-FX	AV-4915-FX

\* A quantity of necessary parts is included in repair kit **KK-4058-1** for complete gun repair and should be kept on hand for service convenience.

# Ref. No. 38 includes Ref. Nos. 12-37.

† Ref. No. 39 includes Ref. Nos. 5, 6 and 11.

Suffixes -K5 and -K10 designates kits of multiple parts.  
Example: AV-1-K5 is a kit of 5 gaskets.

**DEVILBISS**

Customer Service 1.800.992.4657  
And Technical Support 1.888.992.4657

